

# *MinistryStyles Analysis*

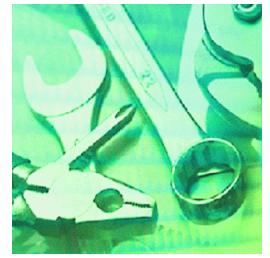

## **Table of Contents For Charlie Brown**

- Personality Outcome
- Processing Blueprint Outcome
- Learning Style Outcome
- Motivational Style Outcome
- Conflict Style Outcome
- Fundamental Needs
- Deductive Style

The *MinistryStyles* Analysis and Outcome Report is designed to describe Charlie in the context of his role in the church body.

For More Information Call or Write:

*MinistryStyles*

ProApse Software  
604 Constance Ave  
Fort Wayne, Indiana 46805

*MinistryStyles* Home-based office (260) 483-6526  
Cell number (260) 615-9839

*NOTE: Accuracy Rating on this Profile is Excellent. Charlie was cooperative and therefore provided useful information.*

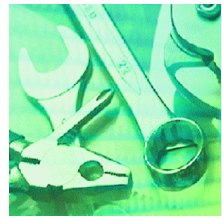

Name: Charlie Brown  
 Address: 123 Main Street  
 City, ST Zip:  
 DOB: eMail: [charlie@proapsesoftware.com](mailto:charlie@proapsesoftware.com)



**TOOLBOX PERSONALITY**  
**Supporter**

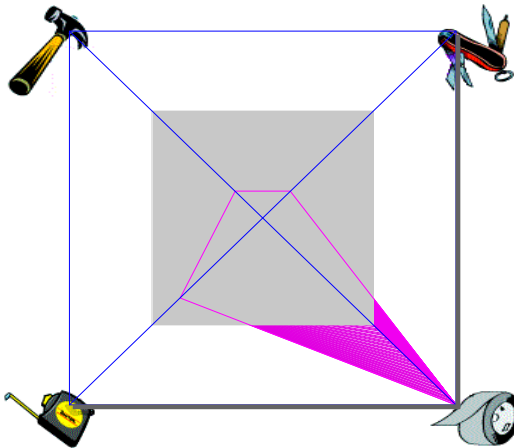

**PERSONALITY UNDER PRESSURE**  
**Pragmatist**

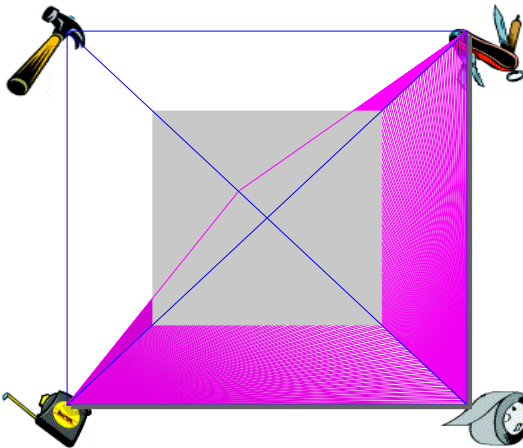

**Motivation Outcome: Why**

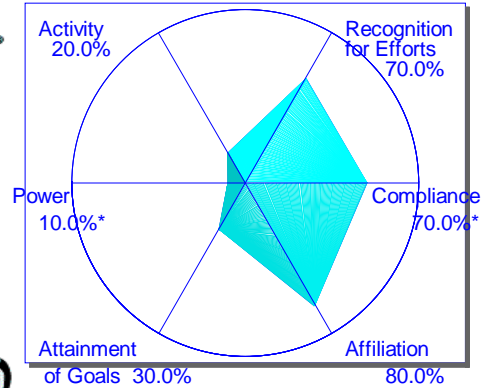

\*May not add to 100% because at least 1 neutral answer was selected.

**Motivation Outcome: How**

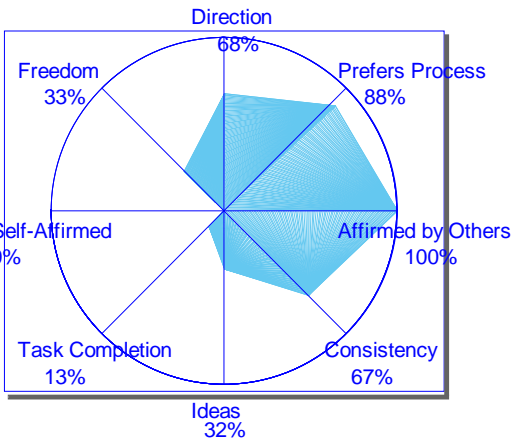

**Conflict Management Outcome**

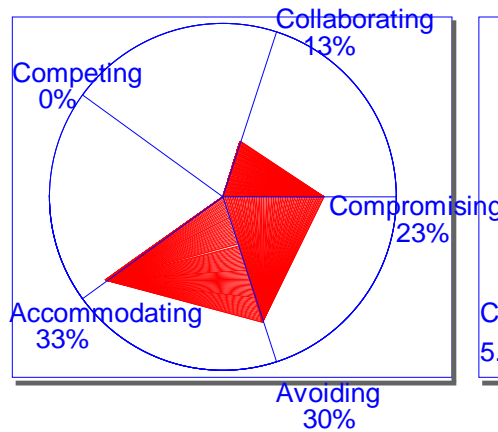

**Fundamental Needs**

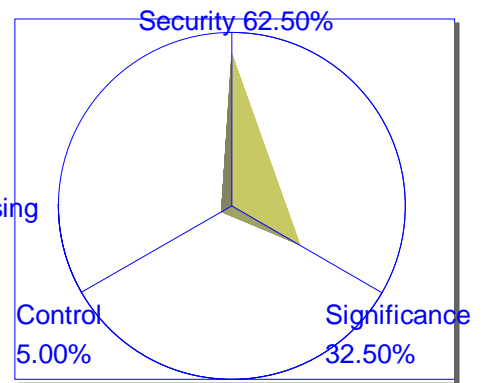

**Deductive Style**

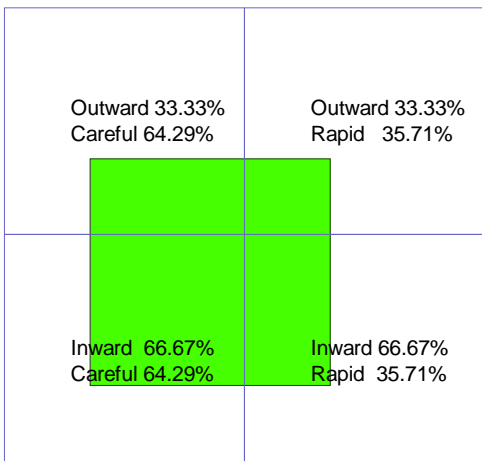

**Processing Blueprint**

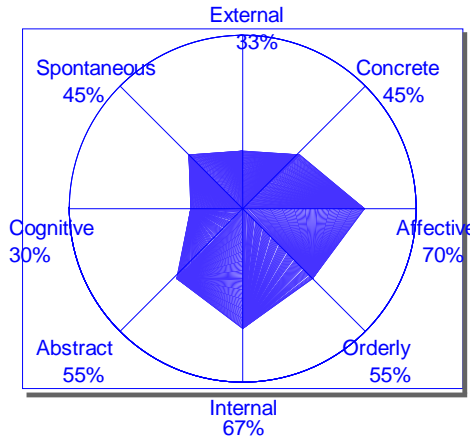

**Learning Style:**

Global, or Analytical?

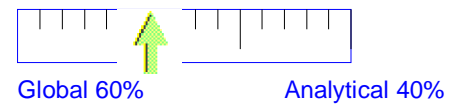

**Motivation Outcome**

Work Conditions vs. Work Function

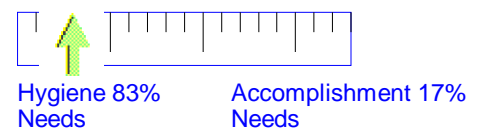

**Accuracy of Results**

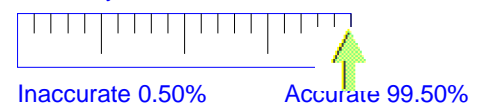



**The "Powerful Hammer"** person needs to understand that the one who holds the hammer should be careful when using it. You can build or destroy with it. Others likely see you as more powerful than you realize. This personality correlates with the Classical Choleric, the High "D" on the Performax DISC, and the Lion in the Trent/Smalley Model.



**The "Versatile Swiss Army Knife"** person is flexible and spontaneous, quickly adapting to most any situation. However, others can at times see you as throwing caution to the wind. This personality correlates with the Classical Sanguine, The High "I" on the Performax DISC, and the Otter in the Trent/Smalley Model.



**The "Adaptable Duct Tape"** person desires to keep the peace and wants everyone to "stick together". However, others may see you as lacking conviction at times, when "making a stand" is important. This personality correlates with the Classical Phlegmatic, the High "S" on the Performax DISC, and the Golden Retriever on the Trent/Smalley Model.



**The "Precision Tape Measure"** likes to "get it right" and seems to have a secret rule book in the back of your mind. However, others may become exasperated when you expect them to comply with your expectations. Learn to be flexible and open to how others view situations. This personality correlates with the Classical Melancholy, the High "C" on the Performax DISC, and the Beaver on the Trent/Smalley Model.

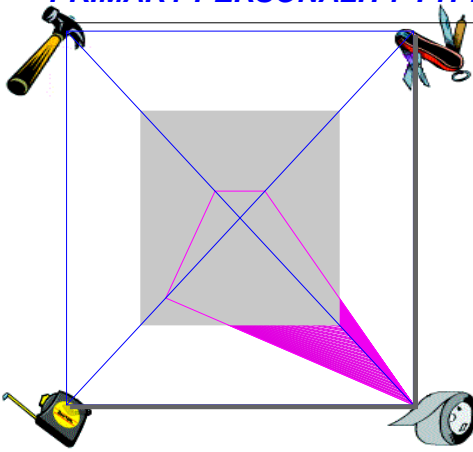

Tool Box Personality: Adaptable Duct Tape  
Classical Designation: Phlegmatic  
**SUPPORTER**

[See the Personality Overview (Page 2) for the names used by other contemporary personality measuring instruments]

**NARRATIVE:**

Individuals with this personality type are typically calm, modest and willing to accommodate others in many situations. They maintain a low profile by blending into work or social situations. Journeymen are usually reliable, working at a steady, consistent and predictable pace, keeping the peace and mediating between contentious people. Others are influenced by their accommodation, pleasant posture and consistency in personal work performance. Charlie is likely to be helpful to those in the workplace who are considered to be his friends. He will probably have few (but

close) friendships. This profile does not describe people who are "movers and shakers", but rather, consistent and supportive in their work style. There is an emotional need to keep the peace, and Charlie may become discouraged if the work setting is full of conflict. He quite possibly avoids having a tense situation, "making waves", or having to make a major change. Fair, prior warning of changes will allow him to make important adjustments and be more consistent in work performance. There can be a considerable amount of emotional energy expended in maintaining a familiar and predictable environment. Rapid change generally creates an uncomfortable environment for this type of person. He is likely to achieve remarkable consistency in work performance when allowed to specialize within a predictable environment. Expressed appreciation and affirmations from work associates and supervisors will go a long way in motivating him.

**BIBLICAL EXAMPLE: JOHN**

*John, disciple of Jesus, is a wonderful example of a Supporter. Being dominantly relational in his style, he easily fit into Jesus' inner circle. In fact, John refers to himself in the Gospel of John as the "disciple whom Jesus loved". Love is a theme that is central in all of John's writings except the book of Revelation. Probably among the most memorable verses in the Bible is John 3:16. "For God so loved the world, that He gave His only son..." John's loyalty and non-intrusive relational capacity is evident throughout his writings. He calls us to "love one another", demonstrates that God Himself is the personification of love, and develops the point in detail: To say that a person loves God requires them to love others, since God is love. It is John who stays by Jesus' side during the darkest times when all others fled, and John who at the foot of the cross is entrusted with the care of Jesus' mother, instructed by Jesus Himself from the cross. John's docile and non-intimidating presence makes him in turn one of the most beloved personalities of Scripture.*

- 1. DYNAMIC ROLE IN THE BODY** Charlie is apt to follow through in order to please others, bringing steadiness and loyalty into the workplace. He typically does not "rock the boat" and gets along well with most. He maintains a steady pace, is consistent, predictable and is a short-term planner.
- 2. EMOTIONAL POSTURE:** May be accommodating, non-threatening, gentle, unassertive, and moderate in approaching others.
- 3. DRIVING IDEAL:** To work in a predictable and controlled environment and maintain the status quo.
- 4. ASSESSES OTHERS BY:** Their commitment to friendship, followed by competency.
- 5. MOTIVATIONAL STYLE:** Being pleasing, accommodating, and consistent in personal work performance.
- 6. RELATIONAL/TASK ORIENTATION:** An individual with this profile is prone to be primarily relational but will complete a task in order to be pleasing to a superior or work associate.
- 7. TEACHING STYLE:** Supporters, by their nature, take care of people, so as teachers they may be sought out by students. They become very uncomfortable when asked to teach a subject with which they are unfamiliar, but often can accomplish more teaching as a member of the class rather than the one delivering the lesson. A great deal of instruction can take place through personal interaction rather than through formal teaching. Supporters may be more comfortable in this role.
- 8. SERVICE OPPORTUNITIES:** Supporters are very willing participants in most types of opportunities. They see service as the Tangible Hand of God, and are eager to participate wherever they can. It is important to allow them to function within their capabilities since a fear of personal failure is a critical barrier for them in any service.
- 9. STUDY METHOD:** Materials are more likely than not studied with the class in mind; visualizing particular people as points are noted. Lighter reading will probably be sufficient material for their preparation, and very likely they will be looking for opportunities to give "the short answer" when questions are raised. Preparation is more about personal comfort with the material rather than an exhaustive and flawless delivery style.

**10. PRAYER:** Although everyone struggles to maintain adequate time in prayer, the Supporter shines in intercessory prayer. Praying for the needs of others is important to many Supporters, although they may find struggles with a willingness to bring their own matters before God. A frustration the this type of person feels in prayer may be a tendency to feel selfish when he makes requests for himself.

**11. PREFERRED LEARNING ENVIRONMENT:** There is a desire for harmony in relationships, an even pace, and a considerate instructor. Informal group studies are often enjoyed more than a formal service, with Supporters often being more willing to listen to discussion rather than actively speaking to the group. This gives them the opportunity to empathize with the group, which often comes naturally for them.

**12. MOBILITY PREFERENCE:** Overnight travel is not enjoyable for Charlie. He prefers consistency, steadiness and regularity in the work environment. Routine is important.

**13. ENVIRONMENTAL STRESSORS:** This personality type is likely to be stressed by conflict, abrupt and unexpected changes, a lack of consideration/appreciation, and lack of predictability.

**14. OVER-USES:** Modesty, passivity, resistance to change.

**15. WHEN PRESSURED:** Charlie is apt to be flexible, adapting to those in authority, and may accommodate the thinking of the group with whom he works. However, if his convictions are "stomped on" there may be a hidden "will of iron".

**16. UNEASY WHEN:** There is change. He fears a disorganized or conflicted environment.

**17. LEADERSHIP:** This type of person leads by an example of loyalty and dependability. He may have a difficult time saying "no" to requests for help. They will look for the agenda that will 1) not be controversial to the body, 2) do the most good for the body, 3) spend the least amount of God's resources. When a Supporter agrees to fulfill a responsibility, it will generally be carried out in any manner they feel is most considerate of those who are involved.

**18. SUMMARY OF STRENGTHS:** Dependable, patient, loyal, a good listener, and cooperative.

#### **MINISTRY PREFERENCE:**

Charlie is likely to work at an even pace and demonstrate an ability to follow through on projects. An individual with this personality pattern is apt to be very loyal. In the job description, Charlie may prefer the opportunity to:

\*Be considerate  
\*Be still

\*Be free of conflict  
\*Experience familiarity

\*Be relational  
\*Follow orders

\*Be single-focused  
\*Support others

#### **TO COMMUNICATE WITH THIS PERSON:**

Because Charlie is likely to be practical, accurate, and organized, there is a tendency to resist change. Approach him in a gentle and non-controversial manner, giving specifics of how things might change. Prepare this person in advance for any significant changes in the work environment. Charlie may be motivated by logic on some occasions and by feelings at other times. It might be good to attempt to understand the effects a change might have on Charlie before implementing those changes.

#### **TO DISAGREE WITH THIS PERSON:**

Charlie will want to know if you are "in this together." Reassurance of the relationship is important since he wants to be seen as a team player. Focus on what is practical and how it has worked in the past. Give the facts and ask Charlie to consider them. Don't press hard for an immediate response. Time to process new ideas is of utmost importance. Appeal to both logic and a sense of "team-ness."

#### **POSSIBLE NEGATIVE PERCEPTIONS THIS PERSON HAS OF OTHERS:**

Charlie may see those with strong personalities as having a "know-it-all" attitude. There may be a tendency to build resentment towards someone who is consistently "pushy." Verbally aggressive people may be annoying and wear him down. They may be seen as "show-offs" who exaggerate.

#### **NEGATIVE PERCEPTIONS OTHERS MAY HAVE OF THIS PERSON:**

Some people who are hard-driving may wonder why Charlie isn't more aggressive at times. Others may see him as overly sensitive and sometimes lacking in productivity. Charlie works at a steady pace, but may be perceived by some as being "pokey." Those with more energetic personalities may have to fight the impulse to light a fire under Charlie to get him going at a faster pace. Steady plodding can be viewed as being unmotivated, which is not necessarily the case.

#### **NOTABLE CHARACTERISTICS:**

Charlie is apt to be seen as friendly, dependable, and loyal. He finds a steady pace that will work and sticks with it. Having the opportunity to focus on a single task, developing skill in a specialty area is important. He is probably seen as steady and moderate in work pace, with a relaxed, mild-mannered style.

**BASIC DESIRES AND INTERNAL DRIVE:**

Charlie most conceivably desires a job that provides a familiar, consistent, and predictable environment. Time to adjust to change is important. There may be a need to focus on one job at a time, doing it thoroughly. He usually prefers to work at one place rather than overnight traveling, doing a job that is repetitive and specialized. He strives to have close relationships with a few associates and is loyal to them.

**NEED FOR POSSIBLE IMPROVEMENT:**

Concealing grievances and holding grudges can be a problem if Charlie does not speak up to let others know what is being experienced. He may be hesitant at times to initiate change because of a desire to maintain the status quo. One concern a supervisor or manager may need to be aware of is that an employee with this profile is not very likely to speak up until a situation is very strained. He may not speak up at all. He is prone to compromise too much in an attempt to keep the peace. There is also a discomfort with change and risk-taking. It would be beneficial in relationships over the long haul if this person would make the effort to stand up for himself by speaking up more. Charlie may be hesitant to accept change; learning to be more flexible would bring more opportunity and benefit co-workers. Effectiveness would increase with more expression of ideas, self-confidence based on feedback from significant others, and maintaining a focus on the important tasks and details. There is a need to learn to cope with a reasonable level of conflict that is bound to occur in the workplace. Accepting change as a natural part of the work world will increase his effectiveness. Asserting personal views and preferences are worthwhile goals.

**HOW TO ENCOURAGE AND MANAGE:**

Charlie wants to work for a "friend" who truly appreciates his contribution. A relaxed, amiable manager who shows appreciation and interest will motivate him toward greater productivity. Using gentle prodding will help Charlie get started. Because he is very likely to be a team player, sincere appreciation and affirmation are important. Having a manager who shows interest in this individual's family is helpful. Allowing him to specialize will increase the possibility of sticking with a particular job setting.

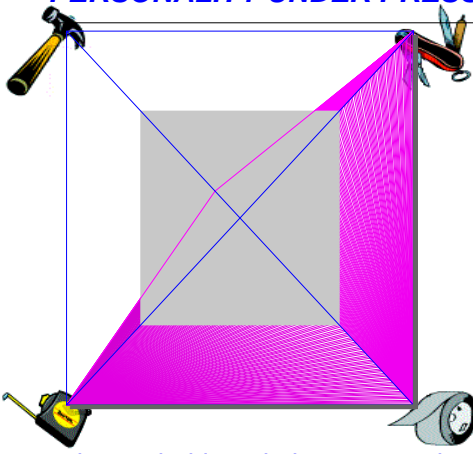

Tool Box Personality: Precision Tape Measure /Versatile Swiss Army Knife/Reliable Duct Tape

**Classical Designation: Melancholy/Sanguine/Phlegmatic Mix  
PRAGMATIST**

[See the Personality Overview (Page 2) for the names used by other contemporary personality measuring instruments]

**NARRATIVE:**

Individuals with this personality pattern typically desire to be proficient in their work and gravitate toward a specialty area. There is an underlying drive to be "good at something". This personality type is frequently conversant on a broad range of subjects. This image can be very positive or hurtful, depending on the perception formed by others. Charlie can be perceived either as a person "in the know" or else as a "know-it-all". He may often project a relaxed and diplomatic style. However,

underneath this style is a person that has an intense focus on achieving high standards of personal performance. Valuing self-discipline, he may judge others by the same bar he sets for himself, even in daily routine. He is apt to verbalize disappointment when these high expectations aren't met. This type of individual likely develops organized approaches to tasks as well as for improving personal skills. Charlie can benefit from appreciating what others contribute to a project, even though they may not do it exactly how he thinks it should be done.

**BIBLICAL EXAMPLE: GIDEON**

*Gideon the Judge is an interesting example of a Pragmatist. People often want to know God's plan for their life but are uncertain how to find it. God made His plan for Gideon clear, but Gideon's need for objective evidence required a careful validation of these plans. Gideon's vision was limited to what he could control - finding food for his family during very adverse times. God's vision for Gideon was much larger, and therefore Gideon effectively led his people against the Midianites, becoming the fifth judge of Israel. Though he was slow to be convinced, he eventually obeyed and overcame his limitations. His people-oriented style suited him for leadership. It is important to note that Gideon's faith was based on tangible evidence, which does not lessen the importance of that faith. A skeptic once assured of the truth, holds that truth with ever-strengthened resolve.*

- 1. DYNAMIC ROLE IN THE BODY:** This person very conceivably utilizes creative ideas and information in order to influence, energize, and entertain people. This person has potential to be proficient in an area of specialization and has a capacity to be a "people problem" solver.
- 2. EMOTIONAL POSTURE:** Desirous of keeping pace with others in areas of performance.
- 3. DRIVING IDEAL:** Has a high ambition for personal growth and achievement.
- 4. ASSESSES OTHERS BY:** Job position and level of self-discipline.
- 5. MOTIVATIONAL STYLE:** Developing and following proper procedures; being an example of mastering new skills.
- 6. RELATIONAL/TASK ORIENTATION:** Charlie has a tendency to be both task and relationally oriented. Interaction with people is very important, but so is the opportunity for adequate preparation.
- 7. TEACHING STYLE:** Very likely, a Pragmatist would be pleased if asked to teach a class, and would do a good job at imparting information found in the curriculum. Depending on the posture he takes, he may appear to be either very knowledgeable, or a "know-it-all".
- 8. SERVICE OPPORTUNITIES:** Very frequently, Pragmatists are willing to jump in and lend a hand. On the positive side of this personality is a willingness to be involved wherever the task defines. On the negative side, the Pragmatist may guard against judgmental feelings toward those that may not have participated in the activity. Delegating responsibility may be a characteristic that needs to be cultivated.
- 9. STUDY METHOD:** Could be very methodical in their approach, reading the materials and taking notes, preparing a lesson with a great deal of joy. Staying with the curriculum would help to keep the lesson on track and to safeguard from some of the personal illustrations which, while possibly appropriate, may tire the class.
- 10. PRAYER:** It is quite possible that Pragmatists struggle with maintaining a regular prayer schedule, being far more likely to approach more tangible activities. Remember that public prayer represents the thoughts of the entire group: some items are better brought before God when you are alone.
- 11. PREFERRED LEARNING ENVIRONMENT:** There is a need for variety in activity that allows time for interaction with people. While Pragmatists enjoy participating in discussion-oriented class sessions, they appreciate knowing the topic in advance in order to at least think through a few issues. Pragmatists tend to see their own strengths while viewing the same

traits in others as weaknesses.

**12. MOBILITY PREFERENCE:** He enjoys a flurry of activity that includes interaction with people, interspersed with "down time" that allows for adequate preparation and/or research.

**13. ENVIRONMENTAL STRESSORS:** Feeling "cut off" from social interaction and experiencing a lack of adequate time for reflection is stressful for Charlie. Also, he is prone to be stressed by the disapproval of others.

**14. OVER-USES:** Can have somewhat unrealistic expectations of himself and others; may place too much attention on personal objectives.

**15. WHEN PRESSURED:** He can become restless, impatient, and critical.

**16. UNEASY WHEN:** Losing in competitive interaction and looking bad in the eyes of others.

**17. LEADERSHIP:** Those with this profile usually have a strong ability to lead with enthusiasm, mobilize the troops, and influence with precise information. Pragmatists are often willing or eager to serve on committees and are likely to contribute very well to the discussion and decision-making. While the Pragmatist may have valuable information, the group may be better-served if they consider alternatives that may not as readily-apparent.

**18. SUMMARY OF STRENGTHS:** Verbal, persuasive, enthusiastic, analytical, cautious, organized, and detailed.

**MINISTRY PREFERENCE:**

With the desire to be logical, this personality type is generally motivated to be accurate, precise, and practical in all that is done. Charlie tends to prefer work that is organized and structured with clear objectives. He will need a variety of opportunities to entertain, meet, and influence people. Expressing creative ideas is also a desire for him. In the job description, Charlie may prefer the opportunity to:

- |              |              |                     |              |
|--------------|--------------|---------------------|--------------|
| *Analyze     | *Be accurate | *Be active          | *Be humorous |
| *Be thorough | *Communicate | *Critique & Improve | *Entertain   |
| *Influence   | *Interact    | *Network            | *Organize    |
| *Perform     | *Plan        | *Process            | *Reflect     |
| *Relative    | *Research    | *Think              | *Verbalize   |

**TO COMMUNICATE WITH THIS PERSON:**

Since individuals with this personality are naturally logical, organized, and accurate, Charlie may tend to resist changes or be too rigid unless there is first an understanding of the reasons why the change needs to occur. Provide the rationale for changes, decisions, or actions through well-researched details, facts, and data. Because of a tendency for Charlie to be relational, persuade him by relating "who" is involved and "who" thinks it's a good idea. Clarify how the new idea may be exciting and fun.

**TO DISAGREE WITH THIS PERSON:**

Carefully document your position with facts and data that have been well researched, and offer proof. Then ask Charlie to consider the case. Do not push him too hard, but rather, give him time to think about the evidence and use logical appeal. Remember this type of personality may need time to process information. Individuals like Charlie can be highly-committed to personal ideas but with time can lose the emotional attachment. Delaying the decision for a few days may possibly open up the door for Charlie to consider other ideas.

**POSSIBLE NEGATIVE PERCEPTIONS THIS PERSON HAS OF OTHERS:**

Charlie may see those with strong personalities as having a "know-it-all" attitude and as overbearing. Also, he may be concerned with others not having the details to make good decisions, feeling that others do not seem to appreciate high standards or have high expectations.

**NEGATIVE PERCEPTIONS OTHERS MAY HAVE OF THIS PERSON:**

Others may see Charlie as being overly concerned with the details. He may appear to be overly emotional or as "blowing in the wind" in some situations. On other occasions this same individual may be perceived as rigid or unbending. Some may feel competitive toward Charlie because of his influential nature and the ability to get the facts together. At times, this personality type may be seen as playing the role of the "expert" and can come across to others as being a "know-it-all". Some may react to Charlie with a "So what? Who cares?" attitude in regard to his high expectations. This person can be seen as fickle because of being so logical on some occasions and very emotional at other times.

**NOTABLE CHARACTERISTICS:**

Others may note that Charlie has a modest, sociable, predictable and cooperative posture. He is likely to be careful, conservative, and minimize risks by careful investigation. Charlie prefers an atmosphere that is free of antagonism, and he

desires harmony. He will most likely seek work-related projects where there is the opportunity to specialize. He can also create and maintain an atmosphere of good will if it is the primary objective.

**BASIC DESIRES AND INTERNAL DRIVE:**

Charlie has a basic desire to be unassuming, dependable, and conscientious. There is an expectation that others will be as considerate and fair in return. This personality type generally respects authority and desires to please. However, in some situations, the desire to please can result in this person becoming caustic, showing a hidden "will of iron" when feeling someone is taking advantage of him. Charlie can be easily hurt by rejection or by being overlooked. There may be a tendency to hang on to that hurt. He wants to avoid contention, conflict, or complications.

**NEED FOR POSSIBLE IMPROVEMENT:**

Charlie may want to develop ways of demonstrating appreciation for others who do things well, even though their method is not what he may think is the "right way." He may be prone to dawdle, hesitate, and deliberate before taking a risk or making an important decision. It may be beneficial to adopt a posture of striving to make a "good decision" rather than a "perfectly safe decision." Charlie is apt to prefer traditional/conventional methods of operating over innovation. Learning to take calculated risks might be beneficial. He may trust people too much and get hurt in the process. Effectiveness would increase with more individual follow-through, sensitivity when showing disapproval or disagreement, identifying the right pace in the work context, showing appreciation to others who do things well (even if not the way he prefers). There may be a need to bring focus to the work situation by having adequate time to process new ideas, by slowing down, and by being disciplined to finish a task on time.

**HOW TO ENCOURAGE AND MANAGE:**

Charlie quite possibly wants to know exactly what is expected in order to do the job well and accurately. There is a need for a relaxed manager or supervisor who will be available to discuss key moves and who will be supportive in difficult situations. Charlie desires to work with a team that is friendly and doesn't mind an unhurried pace. He wants associates to be personally interested and who express sincere appreciation for his contributions.

## Processing Blueprint

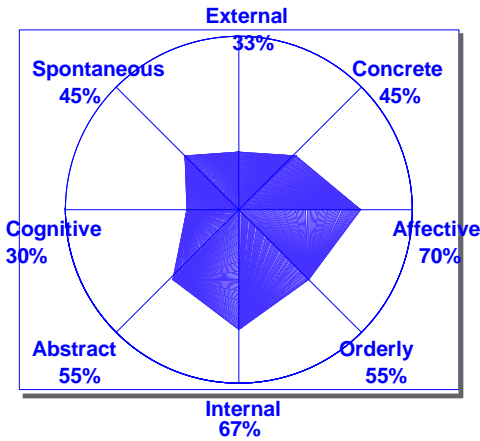

This section of the report explains the following about the individual responding to the MinistryStyles inventory:

1. How Charlie is Energized [Externally vs. Internally]
2. How he Takes in New Information [Concrete vs. Abstract]
3. How he Makes a Decision [Head vs. Heart]
4. How he Relates to the External World [Orderly vs. Spontaneous]

### EVENT INPUT: INTERNAL vs. EXTERNAL ENERGY (Internal) (External)

INTERNALLY Energized and EXTERNALLY Energized are two different ways of relating to our environment. A person who is INTERNALLY Energized prefers to focus on the inner world of ideas and thought. Time alone for reflection is important. This person is not necessarily shy or unsociable. However, the EXTERNALLY Energized person prefers to focus on people and activities, drawing energy from the external world, or those things in which he is involved.

#### INTERNALLY ENERGIZED

- Energized by inner experiences
- Introverted
- Reflects, then possibly acts
- Is often reserved and quiet
- May sometimes be harder to get to know
- More private and restrained
- Needs privacy
- Thinks before speaking and acting
- May seem withdrawn to the extrovert
- Processes information inwardly

#### EXTERNALLY ENERGIZED

- Energized by people
- Extroverted
- Acts, then possibly reflects
- Is often friendly and talkative
- Easy to get to know
- More expressive and unrestrained
- Needs engaging activity
- Discovers thought as words are spoken
- May seem shallow to the introvert
- Processes information outwardly

### SENSORY FILTER: CONCRETE vs. ABSTRACT

At any given time a person is either taking in information or making decisions based upon information already received. Using CONCRETE or ABSTRACT data are two ways of perceiving information. The CONCRETE processor prefers to utilize what can be actually seen, heard, touched, tasted, or smelled, rather than counting on the possibilities of what could be. The ABSTRACT processor prefers to gather information by application and thinking through as many different scenarios as possible.

#### CONCRETE (Factual)

- Prefers handling the practical matters of life situations
- Likes things that are definite and can be measurable
- Starts at the beginning, taking one step at a time
- Reads instructions and notices the details of a given situation
- Likes set procedures and the established routines
- Asks "What do I do in this situation?"

#### ABSTRACT (Intuitive)

- Prefers imagining new possibilities and opportunities in life situations
- Definitely likes opportunities to be creative and inventive
- Jumps in anywhere and tends to pass over the steps
- May skip directions and tends to follow intuitive hunches
- Likes change and variety in the job and personal life
- Asks "What could I do if there are no limitations?"

## INFORMATION PROCESS: COGNITIVE(THINKING) vs. AFFECTIVE(FEELING)

COGNITIVE and AFFECTIVE are two different ways of making decisions. People use both their Head and Heart in making decisions but typically prefer and are better at one over the other. The person that prefers the HEAD (Cognitive) function tends to make decisions based on what seems to be logical with objective information. This does not mean that the individual never makes decisions based on his HEART (Affective). A person that prefers the HEART(Affective) function in making decisions is likely to be more person-centered and/or value-centered. This does not mean that this person is overly emotional or illogical. It is not suggesting that the individual will never make a decision based on his HEAD(Cognitive).

### HEAD(Cognitive)

- Decides with the head
- Goes with what seems to make sense
- Concerned for truth and justice
- Objectivity is important
- May seem aloof and condescending to the Feeling-preferred person

### HEART(Affective)

- Decides with the heart
- Goes by a sense of personal convictions
- Concerned for relational harmony
- Emotionally participates
- May seem fuzzy-minded and emotional to the Thinking-preferred person

## OUTPUT METHOD: ORDERLY VS. SPONTANEOUS

ORDERLY and SPONTANEOUS reflect different lifestyle orientations by which people relate to the external world. A person who has an ORDERLY preference will generally relate to life by being more decisive, planned, structured and organized. Whereas, the person who is more SPONTANEOUS in preference will generally relate to life by being more flexible, adaptable, curious and quick to embrace the change that may come his way.

### ORDERLY

- Prefers an organized lifestyle, tends to organize what is important and may let other things go
- Likes definite order, structure and knowing what is to happen next
- Likes to have life under control and somewhat predictable
- Likes to have clearly defined limits and categories
- Feels comfortable establishing closure and getting something completed
- Enjoys deadlines and likes to plan in advance to prevent undue pressure
- May seem demanding, rigid and up-tight to the more Spontaneous type of individual

### SPONTANEOUS

- Prefers a flexible lifestyle and can adjust with the changes in life's situations
- Likes going with the flow and rolling with the punches
- Prefers to experience life as it happens
- Likes the freedom to be able to explore with minimum limits
- Meets deadlines by the last minute rush with a touch of suspense
- Fulfills tasks by a last minute sprint to the finish line
- May seem disorganized, messy and irresponsible to the Orderly type of individual

The following Information indicates the factors that determine HOW, WHY, and WHAT motivates Charlie. These factors may help determine which managerial style may be most suitable to supervise him.

**Motivation Outcome: How**

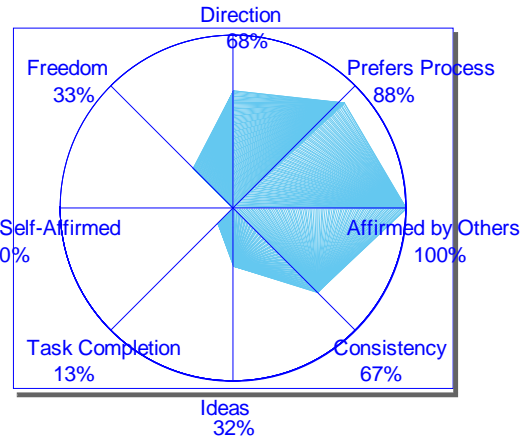

**HOW IS CHARLIE MOTIVATED?**

100% AFFIRMATION vs. 0% SELF-AFFIRMING

Charlie finds self-esteem through appreciation by and the estimate of significant others, rather than directly through self-evaluation.

32% EXCHANGE OF IDEAS vs. 68% DIRECTION

Charlie shows a preference for receiving direction without being required to give input. He does not usually enjoy exploring opportunities or dialoging on ideas, strategies, and challenges.

67% CONSISTENCY vs. 33% FREEDOM

Charlie is motivated by working in a predictable environment. He values consistency and follow-through. He does not like working on his own. Being expected to develop work systems would be intimidating to him.

13% TASK COMPLETION vs. 88% PREFERS PROCESS

Charlie is motivated by the work itself. What is being done and how it is done are very important. Finishing a task or meeting a goal are not rewards; he is ready to address the next process.

**WHY IS CHARLIE MOTIVATED?**

70.0% RECOGNITION OF EFFORTS vs. 30.0% ATTAINMENT OF GOALS

Charlie is motivated by attaining predetermined objectives, standards, goals, and opportunities.

10.0% POWER vs. 70.0% COMPLIANCE

He is motivated by the opportunity to be part of the group effort and cooperation.

80.0% AFFILIATION vs. 20.0% ACTIVITY

Charlie is motivated more by "who" is associated with the situation more than "what" is being done.

**Motivation Outcome: Why**

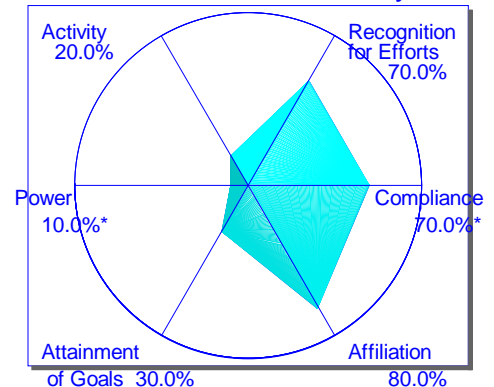

\*May not add to 100% because at least 1 neutral answer was selected.

**WHAT SEEMS TO MOTIVATE CHARLIE?**

Motivation Outcome

Work Conditions vs. Work Function

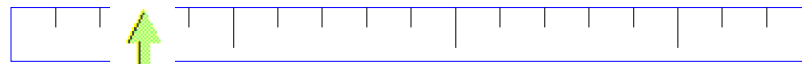

Hygiene 83% Needs

Accomplishment 17% Needs

83% HYGIENE NEEDS vs. 17% ACCOMPLISHMENT NEEDS

Charlie is motivated more by an attractive environment, job security, appropriate compensation, adequate supervision, and satisfactory work conditions.

He is not as motivated by the challenge of achievement, recognition, advancement, or overcoming significant obstacles.

Learning Style explains how the individual interacts with new information. There are two extremes: the GLOBAL learning style and the ANALYTICAL learning style. No person is bound by one learning style. However, even though individuals find themselves in both categories, they gravitate toward just one style.

A GLOBAL learner sees the big picture or overall view, while the ANALYTICAL learner focuses on the parts that make up the big picture. GLOBAL learners hear new information by listening to the "gist" of what is being communicated, quickly getting the main idea or topic. Remembering the details may be somewhat difficult. In following directions the GLOBAL learner listens for "what is supposed to be done", not necessarily "how to do it".

In contrast to the GLOBAL, an ANALYTICAL learner hears new information and tends to listen for specific details. Getting the overall concept that the details describe may be sometimes difficult for the ANALYTICAL learner. In following directions, the ANALYST listens for details and may become particularly frustrated if instructions are repeated.

Charlie's primary learning style is GLOBAL

Learning Style:  
Global, or Analytical?



Global 60% Analytical 40%

**Characteristics of the Global Learner**

- Learns by discussion and cooperates in group efforts
- Does several things at once and may skip steps/details
- Sees the big picture and relationships between ideas
- Reads between the lines and sees many options
- Works hard to please and tries to avoid conflict
- Goes with the flow and is generally flexible
- Tends to avoid individual competition
- Paraphrases in explaining a perspective

**Frustrations of the Global Learner**

- Having to show the steps used to arrive at a particular answer
- Accepting criticism of others without taking it personally
- Not knowing the purpose for doing a particular task
- Not receiving enough credit for the efforts made
- Having to explain something analytically and in detail
- Having to go step-by-step without knowing the outcome
- People who are insensitive to the feelings of others
- Not getting a fair chance to explain oneself

**Characteristics of the Analytical Learner**

- Likes going step-by-step in a sequential order
- Typically self-motivated, logical, and focused
- Must be prepared and needs to know what to expect
- Pays close attention to details and specifics
- Can find the facts but may miss the main idea
- Often values facts over intuition and feelings
- Remembers specifics and prefers organization
- Prefers to finish one thing at a time
- Has a sense of fairness
- May prefer direct answers

**Frustrations of the Analytical Learner**

- Listening to a long explanation when all that is needed is a simple "yes" or "no" response
- Listening to an overview without knowing the steps involved
- Not understanding how an employer/instructor evaluates
- Not finishing one task before going on to the next
- Having opinions expressed as fact without evidence
- Not having an understanding of the purpose of the task
- Dealing with broad generalities and not having the specifics

The following Five Styles of Conflict Management are presented in the MinistryStyles Outcome Reports:

**Conflict Management Outcome**

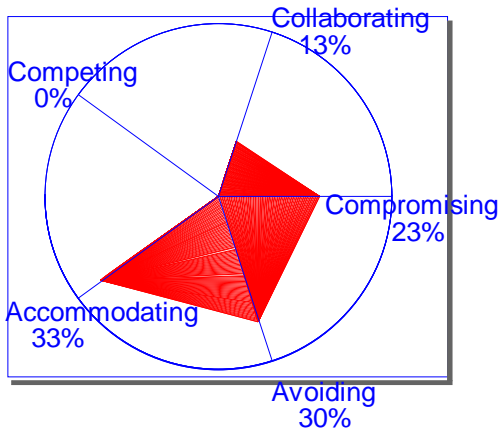

- Accommodating
- Avoiding
- Competing/Forcing
- Compromising
- Collaborating

This individual's style of dealing with conflict is...

Primarily **ACCOMMODATING**  
 Secondly **AVOIDING**

**ACCOMMODATING**

**POSTURE:** "I'll lose so you can win!"  
**ATTITUDE:** "Whatever you say!"  
**STRATEGY:** Agree, flatter, appease, anything to keep the peace.  
**PREFERS OTHERS:** Who will force the issue, or those who may be willing to collaborate.  
**INTERACTION:** Very reluctant to enter into a tense dialogue or to gather uncomfortable information.  
**LEADERSHIP STYLE:** Ineffective in groups, easily swayed, needs to appease, takes tangents in discussions at times.  
**GOAL / RELATIONS:** Has a concern for preserving the relationship in the conflict, even at the price of giving up personal desires and goals.

**IMPORTANT VERSE:** 1 Corinthians 6:7  
*The very fact that you have lawsuits among you means you have been completely defeated already. Why not rather be wronged? Why not rather be cheated?*

**AVOIDING**

**POSTURE:** "I don't want to make any waves, so I'll steer clear of conflict."  
**ATTITUDE:** "Conflict? What Conflict?"  
**STRATEGY:** Flee, deny, ignore, withdraw, delay, hope, wish & pray; just get away from the conflicted situation.  
**PREFERS OTHERS:** Who tend to avoid as well and do not make waves.  
**INTERACTION:** Reluctant to enter into any kind of tense dialogue or gather uncomfortable information.  
**LEADERSHIP STYLE:** Passive or timid, inclined to moralize; aimed to "weather the storm" and can be unfocused as a leader.  
**GOAL / RELATIONS:** Feels at times that it is impossible to accomplish one's goals in a conflicted situation.

**IMPORTANT VERSE:** Romans 12:18  
*If it is possible, as far as it depends on you, live at peace with everyone.*

**Fundamental Needs**

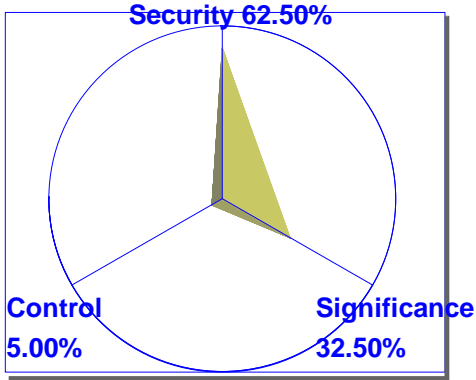

There are three fundamental needs that everyone experiences in life. However, one will usually dominate and contribute significantly to a person's outlook, attitude, motivation, and behavior. The following are the Fundamental Needs:

- \* **SECURITY** comes by way of acquisition of assets, position, education, or a sense of belonging. Those motivated by security are likely attracted to a career setting that provides for a stable future.
- \* **SIGNIFICANCE** comes by way of approval or affection from significant others. It brings a desire for a career setting that has a positive effect on others. This usually comes about through cooperative efforts or association with a particular group of people.

\* **CONTROL** manifests itself in efforts to influence or manage circumstances or people. It carries a longing for a setting that will allow the opportunity to control the work setting or have the power to manage people/events.

**Principles that Apply to Fundamental Needs**

- One of the three Fundamental Needs will be dominant throughout most of a person's life, but many people will identify a Secondary Need as well.
- Fundamental Needs have a significant impact on one's attitude, behavior, and motivation in the work context.
- A mis-managed Fundamental Need can become a destructive force in any area of life.
- Setbacks may cause a temporary shift away from the Fundamental Need to the Secondary Need.
- Identifying a Fundamental Need can increase the understanding of a person's attitudes, motivation, and behavior.

Charlie's Primary Need is to achieve a sense of **SECURITY (62.50%)**.

His Secondary Need is to achieve a sense of **SIGNIFICANCE (32.50%)**.

Deductive Style

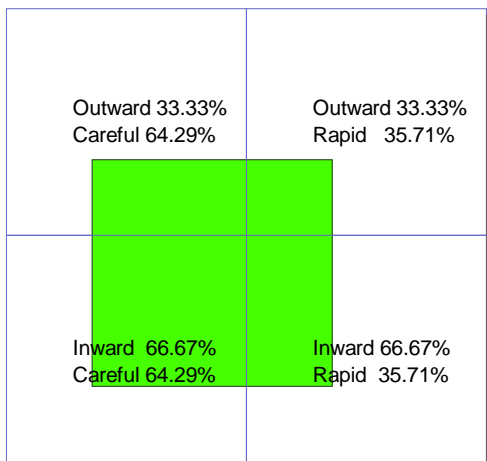

PROCESSING /DECISION MAKING STYLE

People have 4 different ways of processing information and making decisions.

Outward or Inward Processors

Careful or Rapid Deciders

Charlie is an Inward Processor and a Careful Decider

Outward Processors

Inward Processors

Careful Decider

Rapid Deciders

SPECIAL NOTE: As the indicator box moves toward the center of the graph, uadrants, the individual uses flexibility and adaptability in the decision-making style. In contrast, when the deductive style is charted almost fully over a single quadrant it may be problematic. A deductive style that positions almost fully over a single quadrant it may be problematic. Clockwise from upper left:

- \*OUTWARD/CAREFUL: INDECISIVE
- \*OUTWARD/RAPID: IMPULSIVE
- \*INWARD/CAREFUL: EVASIVE
- \*INWARD/RAPID: SUBVERSIVE

Outward Processors often utilize interaction with others as a way to process information and arrive at a wise decision. They have a need to communicate their thoughts openly in order to discern which ideas best contribute to a wise decision. It is this interaction with others that allows them to convert an idea to a decision. Others may think this type of person 'thinks out loud', allowing others to hear both their good and bad ideas. Some may get the impression that Outward Processors figure out what they think as they speak. Observers may not fully understand the need for engaging conversation in order for the Outward Processor to organize and clarify the thinking process. When this person is in a leadership role, others cannot always tell whether an outward Processor is just 'thinking out loud' or making a decision. Thoughts are often discovered as words are spoken.

Inward Processors may unfairly evaluate the Outward Processor as shallow or careless with their thoughts.

Inward Processors usually keep their thoughts private until they are convinced that the ideas are sound. They sort through their thoughts privately, and discern which ideas best contribute to a wise decision. It is in their private world that they can solidify their decisions. Others may think of this kind of person as one who 'holds their cards close' or even as 'uptight' about sharing thoughts. Some may get the impression the Inward Processor is unwilling to take the risk of sharing all their ideas. Inward Processors may be accused of not being open to the exchange of ideas, failing to fully understand their need for privacy in order to organize and clarify the thought process. In a leadership position others cannot always get a 'reading' on what the Inward Processor is thinking. This type of person is usually only willing to share ideas that they are convinced are wise. Outward Processors may unfairly see the Inward Processor as uninvolved, non-committal, or withdrawn.

Careful Deciders usually have to investigate all the options before making a decision, wanting to be certain of the outcome. They tend to go step-by-step with a methodical style of processing information and arriving at decision. They often display a need to investigate numerous options with a treadmill-type of thinking process. Others may see this kind of person as 'bogging down' the process or as being overly concerned over small matters.

Rapid Deciders have a quick sense of what will work and are able to intuitively process information and arrive at a decision without the need to go step-by-step. Others may see this kind of person as 'rushing to judgment', carelessly making decisions, which may or may not be the case.

## Additional Resources Helpful in Understanding Work Styles

**An Adult Guide to Style.** A. Gregorc, Columbia, CT: Gregorc Assoc., 1982  
(Useful in gaining a deeper understanding of your learning style)

**Different Children, Different Needs.** C. Boyd & D. Beohi, Sisters, OR: Multnomah Press, 1994.  
(Understanding personality-based needs)

**Find the Career That Fits You.** L. Ellis & L. Burkett, Gainsville, GA: Career Pathways, 1995.

**Personal DISCernment Inventory.** J. Mohler, Alanta, GA: Team Resources, 1976.  
(Correlates with the MinistryStyles Toolbox Personalities)

**Personal Profile System.** Carlson Learning Co., Minneapolis, MN: Carlson Learning Co. 1994.  
(Useful in gaining a better understanding of your own personality.)

**Personality Analysis.** L. Burkett, Gainsville, GA: Career Pathways, 1995.

**Personality Plus.** F. Littauer, Tarrytown, NY: Fleming H. Revell, 1983.

**Personality Puzzle.** F. Littauer, Grand Rapids, MI: Fleming H Revell, 1992.

**The Two Sides of Love.** G. Smalley & J. Trent, Colorado Springs, CO: Focus Publ., 1990.  
(The Lion/Otter/Golden Retriever/Beaver Personality Model)

**The Way They Learn.** C. Tobias, Colorado Springs, CO: Focus on the Family, 1994.  
(Understand a child's learning style)

**The Winning Hand - Making the Most of Your Family's Personality Differences.** W. Rickerson,  
Colorado Springs, CO: NAV Press, 1991.

**Understanding How Others Misunderstand You.** Voges & Braund, Chicago, IL: Moody, 1991.  
(Gain a better insight into personality-based conflict)

**Your Career in Changing Times.** L. Ellis & L. Burkett, Gainsville, GA: Career Pathways, 1995.